

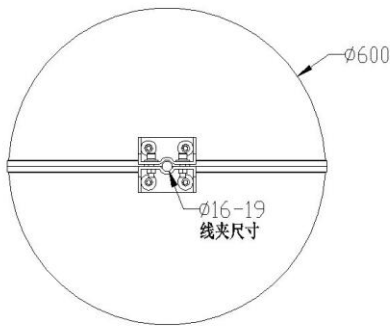

Mounting dimension (unit : mm)

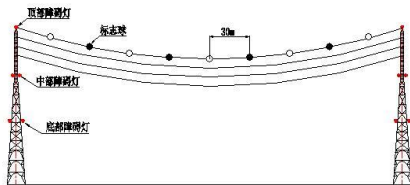

Application



Application

Designed to use for high-rise transmission lines, especially for EHV (500,000KV) transmission cables, river-crossing transmission lines to provide the warning marks.

Main functions and features

- colored weatherproof glaze
- corrosion resistance, ambient temperature: -40°C ~ +90°C , Can be used under very hostile conditions.
- Normal screw mounting, distribute bushings
- FRG material property: Tensile strength≥128MPa; flexural strength≥230MPa; Barcol hardness≥44

Specifications

Standard	Conforms to ICAO Item 14
color	white/red/orange/orange and white/orange and red
Cable clamp	Cable diameterΦ16~Φ19 including bushing or designated
Ambient temperature	-40°C ~ +90°C
size	600*2.2mm/800*2.2mm/130*2.2mm
weight	< 15Kg
Material	sphere : FRG clamp : die-casting alloy

Installation

- Mounted on the wire rope of lightning protection ground of the overhead tower. The distance between each two spheres is the following:
 - a, if the diameter of sphere is 600mm, the distance is no more than 30m
 - b, if the diameter of sphere is 800mm, the distance is no more than 35m
 - c, if the diameter of sphere is 1300mm, the distance is no more than 40m, Equal Interval setting .

- It has red, white, orange. The setting should be interphase.
- Involved multiterm lines, cables situation, the height of the spheres should not be lower than the height of the highest marked overhead line.

Note:

- Line diameter can not exceed the range regulated by the clamp, designated for the special situation.
- Choose two different colors spheres at the meanwhile, interphase setting.

